

# PoE Series CS-1005G-4PX

5 Port 10/100/1000M Gigabit Switch with 4 Port PoE+



## User's Guide

### FCC Certifications



This Equipment has been tested and found to comply with the limits for a Class A digital device, pursuant to part 15 of the FCC Rules. These limits are designed to provide reasonable protection against harmful interference when the equipment is operated in a commercial environment. This equipment generates, uses, and can radiate radio frequency energy and, if not installed and used in accordance with the instruction manual, may cause harmful interference to radio communications.

Operation of this equipment in a residential area is likely to cause harmful interference in which case the user will be required to correct the interference at his own expense.

This device complies with Part 15 of the FCC Rules. Operation is subject to the following two conditions: (1) this device may not cause harmful interference, and (2) this device must accept any interference received; including interference that may cause undesired operation.

### CE Mark Warning



This equipment complies with the requirements relating to electromagnetic compatibility, EN 55022 class A for ITE, the essential protection requirement of Council Directive 89/336/EEC on the approximation of the laws of the Member States relating to electromagnetic compatibility.

Company has an on-going policy of upgrading its products and it may be possible that information in this document is not up-to-date. Please check with your local distributors for the latest information. No part of this document can be copied or reproduced in any form without written consent from the company.

#### Trademarks:

All trade names and trademarks are the properties of their respective companies.  
Copyright © 2016, All Rights Reserved.

## Unpacking Information

Thank you for purchasing our PoE series products. Before installation, please check that your package contains the following items.

**Open the shipping cartons of the switch and carefully unpack its contents. The carton should contain the following items:**

1. CS-1005G-4PX Main Unit x1
2. Quick Installation Guide Booklet x1
3. Power Adapter x1
4. Warranty Card x1

## Application

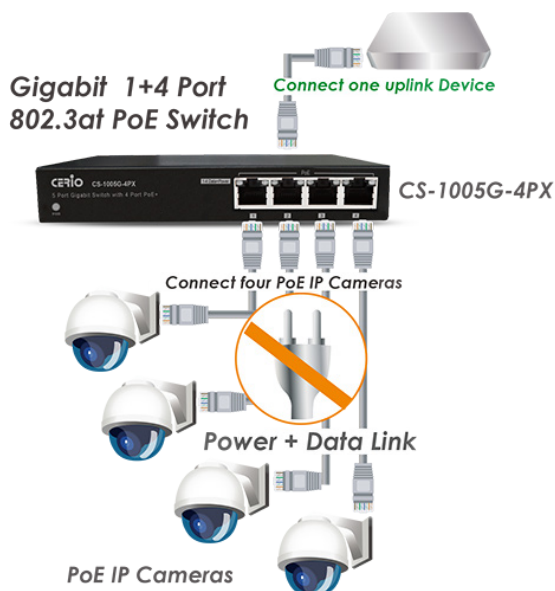

## Introduction

### Power Over Ethernet

The CERIO CS-1005G-4PX is a powerful and complying with IEEE 802.3af/at Power over Ethernet standard which provides DC 48~57V Gigabit over Ethernet cables high-performance Gigabit Ethernet switch, with all 5 ports capable of 10/100Mbps or 1000Mbps auto negotiation operation which means the switch could automatically negotiate with the connected partners on the network speed and duplex mode. It is ideal for micro-segmenting large networks into smaller, connected subnets for improved performance, enabling the bandwidth demanding multimedia and imaging applications. Moreover, the 10/100/1000Mbps autosensing ability provides an easy way to migrate 10Mbps to 1000Mbps network with no pain.

The CS-1005G-4PX supports 4 Port 10/100/1000M Gigabit port Power over Ethernet (PoE+) allows you to expand your network via Ethernet cable to where there is no power line or outlet but where you want to fix devices such as APs, IP Cameras or IP Phones, etc.. No longer need to worry about the complicated cables and long distance which may cost you a lot of time and money. By integrating the data transmitting cable and power cord, it eliminates the effort constructing your network. Over current protection and circuit shorting protection are also supported to ensure the safety. It also support desk top and wall mounting for easy installation.

### Key Features

- Complying with IEEE 802.3 10Base-T, IEEE 802.3u100Base-TX, IEEE 802.3ab 1000Base-T, IEEE 802.3afPoE, IEEE 802.3at PoE+
- 5 Ports 10/100/1000Mbps Auto-Negotiation Gigabit Switch, including 4 Ports PSE/ PoE+ function, complying with IEEE 802.3af/at standard
- Supporting the power up to 30Watt/15.4Watt/7.5Watt/4Watt for each PSE/PoE+ port with bundle 65Watt Power Adapter and have 60Watt share for 4 PoE ports (Only POE Port 1-4)
- Full/Half-Duplex capability on each TX port
- Supports Store & Forward architecture and performs forwarding and filtering
- Auto-learning networking configurations
- Supporting the flow control: back pressure for Half duplex and IEEE 802.3x for Full-duplex mode
- Support Jumbo Frame 9K
- Non-blocking & Non-head-of-line blocking full-wire speed forwarding
- Supports TP interface Auto MDIX function for auto TX/RX swap
- Automatic Source MAC Address Learning and Aging
- Supports up to 2K MAC addresses
- Up to 1Mb bits buffer

## Installation

The setup of the switch can be performed using the following steps:

- Visually inspect the DC jack and make sure that is fully secured to the power adapter
- Make sure that there is proper heat dissipation from and adequate ventilation around the Switch. Do not place heavy objects on the Switch

### Cables Installation

The Switch support 5 port 10/100/1000Mbps Gigabit Ethernet ports and Port 1 – Port 4 are Gigabit PoE Enabled ports, these PoE port will automatically activate when a compatible terminal is identified. The Switch will supply power through the Ethernet port to the connected PoE powered device (PD) For legacy devices that are not compatible, the PoE port will not offer power to this device. This feature allows users to freely and safely mix legacy and Power over LAN compatible devices on their network.

The Switch supports 10Mbps Ethernet or 1000Mbps Gigabit Ethernet and it runs both in half and full duplex mode using two pair of Category 5 cable. These RJ45 ports are Auto-MDI type port. The Switch can auto negotiate the MDI-II or MDI-X type, so you can connect any RJ-45 cable regardless if it is a standard or crossover cable.

### Gigabit PoE Ports (Port 1~4)

These ports are 802.3af (PoE) and 802.3at(PoE+), the PoE port will automatically activate when a compatible terminal is identified. The PoE switch will distribute power through the Gigabit ethernet ports to the connected PoE device. For devices that are not compatible, the PoE port will not supply the power to this device. This feature allows user's to freely and safely utilize the 802.3af (PoE) and 802.3at(PoE+) for Power over Lan devices on their network.

### Gigabit Ethernet Port (Port 5)

These ports support network speeds of either 10Mbps or 100Mbps or 1000Mbps, and can operate in half and full-duplex transfer modes. These ports also support automatic MDI/MDIX crossover detection

### Hardware Overview

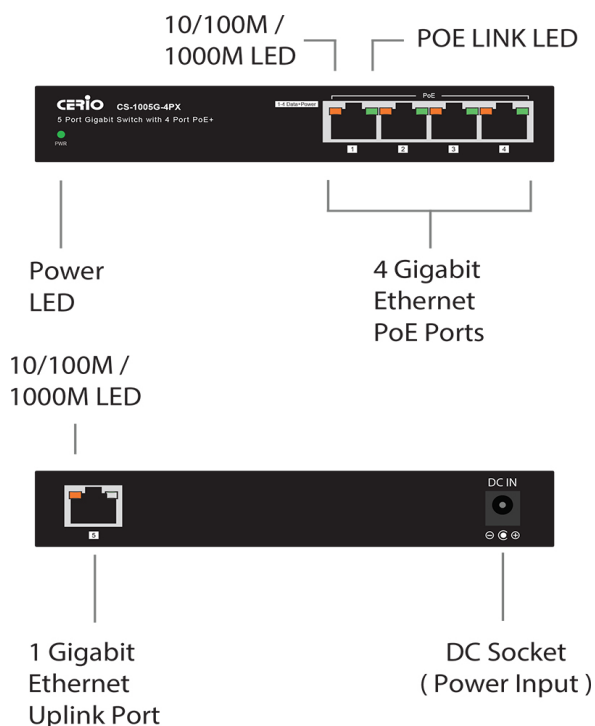

### LED Indicator:

Complete LED indicators displays the status of the PoE Switch and network status

The front panel LEDs provides instant status feedback, and assists to monitor and troubleshoot when required.

### Power LED Power : (Power Indicator)

On :	Power On
Off :	Power Off

### PoE LEDs (Port 1 ~ Port 4) (PoE Status)

Green :	When the PoE powered device (PD) is connected and the port distributes power successfully
Off :	When the PoE port has failed, possible reason are: PoE Power circuit shortage Power over current: over the power current of PD's classification Out of PoE voltage of 48 ~ 57 VDC output No PoE power device (PD) connected

### LINK/ACT Status LEDs (Ports 1~5)

Green	The port is 1000M Link / Act connected.
Blinking Green	A valid link is established, and there is data transmitting/receiving.
Amber	10/100M Link / Act connected.

## Product Specifications

### Standards & Hardware Specifications

<b>Network Standards Conformance</b>	IEEE 802.3 10Base-T IEEE 802.3u 100Base-TX, IEEE 802.3ab 1000Base-T, IEEE 802.3x Flow Control IEEE 802.3af Power over Ethernet (PoE) IEEE 802.3at Power over Ethernet Plus (PoE+) 5ports RJ-45 connectors for 10/100/1000Mbps (With 4 Ports PSE/ PoE+ function )
<b>Port Configuration</b>	CSMA / CA
<b>Media Access Protocol</b>	10BASE -T: UTP Cat. 3 or up, 100BASE-TX: UTP Cat. 5 or up, 1000BASE-T: UTP Cat. 5 or up
<b>Network Media</b>	Store and Forward
<b>Transmission Method</b>	2K
<b>MAC Address Table</b>	1M bits
<b>Built-in Buffer</b>	9K
<b>Jumbo Frame</b>	10/100/1000Mbps (Half-duplex), 20/200/2000Mbps (Full-duplex)
<b>Data Transfer Rate</b>	Yes
<b>Auto MDI/MDIX</b>	Per Gigabit Port:(Link/Act): Status x 5 PoE : Status x 4 Per Unit: Power x 1
<b>LED Indicators</b>	10Gbps
<b>Internal Bus Speed</b>	

### Environmental & Mechanical Characteristics

<b>Power Supply</b>	65Watt External Power Adapter
<b>PoE Power Budget</b>	60Watt shared for all PoE Ports
<b>Power Consumption</b>	1.5Watt
<b>PoE Power Output</b>	Up to 30W per port (for Ports 1-4 Only )
<b>Power Requirement</b>	DC In : Input Voltage: 48 ~ 57Volt
<b>Operating Temperature</b>	0° to 55° C
<b>Storage Temperature</b>	-40° to 70° C
<b>Operating Humidity</b>	10% to 90% non-condensing
<b>Storage Humidity</b>	5% to 90% non-condensing
<b>Dimension ( W x H x D )</b>	160 x 85 x 25mm
<b>Unit Weight</b>	0.345kg
<b>Case of Materials</b>	Metal
<b>Production Location</b>	TW Only
<b>Certification</b>	FCC, CE, RoHS-compliant