

FPOE-MG-E90

4Pair 90Watt Force Power Multi Gigabit Edge PoE Adapters



User's Guide

FCC Certifications



This Equipment has been tested and found to comply with the limits for a Class A digital device, pursuant to part 15 of the FCC Rules. These limits are designed to provide reasonable protection against harmful interference when the equipment is operated in a commercial environment. This equipment generates, uses, and can radiate radio frequency energy and, if not installed and used in accordance with the instruction manual, may cause harmful interference to radio communications.

Operation of this equipment in a residential area is likely to cause harmful interference in which case the user will be required to correct the interference at his own expense.

This device complies with Part 15 of the FCC Rules. Operation is subject to the following two conditions: (1) this device may not cause harmful interference, and (2) this device must accept any interference received, including interference that may cause undesired operation.

CE Mark Warning



This equipment complies with the requirements relating to electromagnetic compatibility, EN 55022 class A for ITE, the essential protection requirement of Council Directive 89/336/EEC on the approximation of the laws of the Member States relating to electromagnetic compatibility.

Company has an on-going policy of upgrading its products and it may be possible that information in this document is not up-to-date. Please check with your local distributors for the latest information. No part of this document can be copied or reproduced in any form without written consent from the company.

Trademarks:

All trade names and trademarks are the properties of their respective companies.
Copyright © 2016, All Rights Reserved.

Unpacking Information

Thank you for purchasing our Force Power Edge PoE series products.
Before installation, please check that your package contains the following items.

Open the shipping cartons of the Edge PoE Adapters and carefully unpack its contents. The carton should contain the following items:

- 1. FPOE-MG PSE (Unit1) x 1**
- 2. FPOE-MG PD (Unit2) x 1**
- 3. Inside diameter 2.1 (PHY) mm DC to DC cable x 1**
- 4. 90W Power Adapter x 1**
- 5. Quick Installation Guide x 1**
- 6. Warranty Card x 1**

Hardware Overview

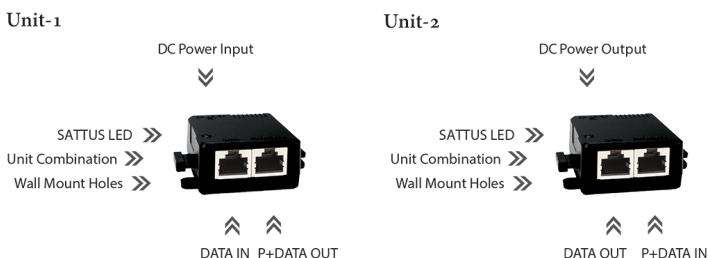

Introduction

The CERIO FPOE-MG-E90 is a Passive type Multi Gigabit Edge PoE Adapters. It provides DC 50-57V over Ethernet cables. Provides a reliable hardware solution for demanding of 802.3bt Type3/Class5 45Watt、Class6 60Watt and Type4/Class7 72Watt、Class8 90Watt PoE power level PoE/PD powered devices. Simultaneously transmit network data and power to the PD equipment through the 4Pair UTP Ethernet Cable transmission. This Force Power PoE++ Injector series provides entry-level applications.

Functionality

The Cerio FPOE-MG-E90 are able to extend PoE to the Edge PoE equipment (Such as small PoE Switch) to delivery power and data to PD device through the 4Pair UTP Ethernet cable connecting the PSE and PD unit. Through RJ45 UTP cable providing both power and data for where power outlets are not readily available. And without limited by the distance and location of outlet sockets. It provides 802.3bt Type3/Class5 45Watt、Class6 60Watt and Type4/Class7 72Watt、Class8 90Watt PoE power level for PD device,, such as the "Supper-speed Multi-Giga WiFi AP" and "Multi-Giga industrial PC" provide a stable high power PoE++ powered solution.

Highlight Features

- Supports 1 / 2.5 / 5Gbps Multi Gigabit Ethernet and Complying with IEEE 802.3 10Base-T, IEEE 802.3u 100Base-TX, IEEE802.3ab 1000Base-T, IEEE 802.3bz 2.5G / 5G BASE-T standard
- Provides Force Power PoE++ output ability, and low cable-loss which can maintain 90Watt PoE power up to 100 meters distance when using CAT 6 or up cabling
- PSE Unit supports PSE / PoE function, max PoE output up to 802.3bt Type4 Class 8 (90Watt) power level
- PD Unit supports PD/PoE function, max PD power up to 802.3bt Type4 Class 8 (90Watt) power level when bundle use with PSE unit
- Supports ESD , Electro Static Discharge protection includes Over Voltage protection and Short Circuit Protection ensuring device safety
- Some additional benefits of Cerio Force Power Multi Gigabit Edge PoE Adapters include cost saving, convenience in network planning, and higher reliability.
- Supports desktop, wall mounting installation and multiple units combination easy to use

Installation

Before Installation

Cerio Force Power Multi Gigabit Edge PoE Adapters are able to extend PoE to the Edge PoE equipment (Such as small PoE Switch) to delivery power and data to PD device through the 4Pair UTP Ethernet cable connecting the Unit-1 and Unit-2.

Cables Installation

Cerio Force Power Multi Gigabit Edge PoE Adapters can provide both data and power for distances of up to 100 meters from the power source (90Watt) and without cable-loss when using CAT 6 or up cabling.

The setup of the Edge PoE Adapters can be performed using the following steps:

Unit-1 (PSE for Uplink Source and POE Downlink connection):

- Connect the included 90Watt power supply DC power Cable to the "DC Jack Port" of Unit1
- Connect your Ethernet cable (Cat6 or up cable) from your data source to the "Data In port" of the Unit-1
- Connect an Ethernet cable (Cat6 or uplink cable) from the "PWR + Data Output Port" of "Unit-1" to your "Unit-2" with an extended distance (Max.100 meters) for Get power extension to end device enable devices.

Unit-2 (PD for POE receive and DC / DATA splitter connection):

- Connect "Power+Data" port on "Unit-2" and "PWR+ Data Out" port form "Unit-1" with Ethernet cable, make sure "Power" LED of "Unit-2" is on.
- Connect "Power OUT" cable on "Unit-2" to power DC Jack of the network end device and connect "Data OUT" cable on "Unit-2" to RJ45 port of network end device. (Ex. Edge. POE Switch for end POE Device such as POE IPCAM or POE WIFI AP)

Check whether the network device is LED on. If not, please make sure that power is on for Unit-1 and Unit-2, and all cables are connected correctly.

Units Combination

This device can be locked on the wall, (**Does not have screw attachment, you must prepare it yourself**) or it can be combined with multiple units for easy to bundles organize the Ethernet cables

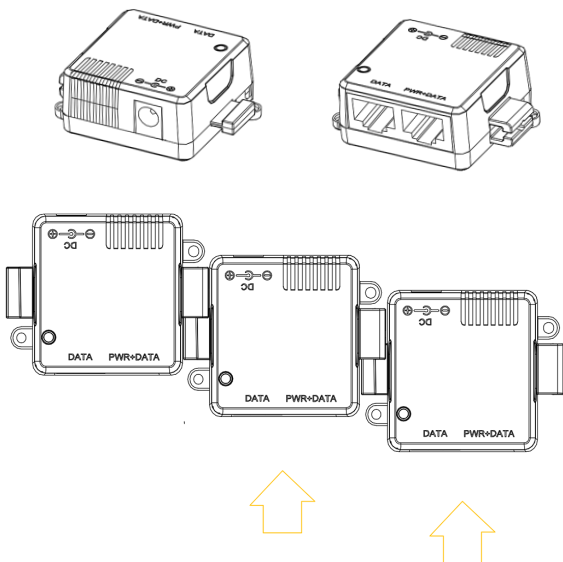

Product Application



Connect data uplink from source Multi-Giga switch

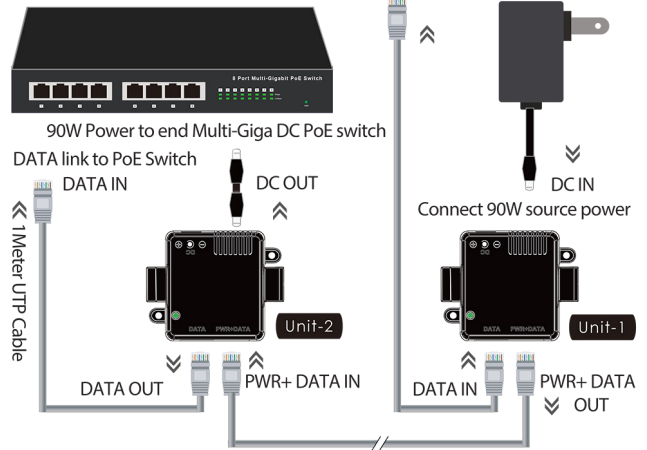

Cat6A. RJ45 UTP Cable 100Meter

Transfer 90W PoE Power up to 100M distance

Notice: Cable and Power Loss

@ 100Meter : Keep power source ability (60Watt) with Cat.6 or up Cable

@ 100Meter : " 14Watt " with Cat.5e Cable

Product Specifications

Standards & Hardware Specifications

Standard	IEEE802.3 10BASE-T IEEE802.3u 100BASE-TX IEEE 802.3ab 1000BASE-T IEEE 802.3bz 2.5G/5GBASE-T 10BASE -T: UTP Cat. 3 or up 100BASE-TX: UTP Cat.5 or up 1G/2.5G/5GBASE-T : UTP Cat.5e or up 10M/100M/1G/2.5G/5G (Half-duplex), 20M/200M/2G/5G/10G (Full-duplex)
Network Media	Passive POE
Data Transfer Rate	PIN 1/2, 3/6 & 4/5, 7/8
PoE Type	End-span (Type-A): PIN 1/2,3/6 Mid-span (Type-B): PIN 4/5,7/8
Data PIN	RJ-45 x1 for Power + Data
Power PIN	RJ-45 x1 for Data
Ethernet Connector	DC Jack
Power Connector	Supports ESD (Electro Static Discharge) Over Voltage protection and Short Circuit Protection
ESD Protection	

Environmental & Mechanical Characteristics

Max Power Output	90Watt
Power Requirement	56V 90Watt External Power Supply
PoE Input Voltage	50V~57V
Cable and Power Loss	@ 100Meter : Keep power source ability (90Watt) with Cat.6 or up Cable @ 100Meter : " 14Watt " with Cat.5e Cable
LED Indicators	System LED: Power (Green) x1
Operating Temperature	0° to 55° C
Storage Temperature	-40° to 70° C
Operating Humidity	5% to 90% non-condensing
Storage Humidity	5% to 90% non-condensing
Dimension	64.8 x 51.7 x 24mm (W x D x H)
Unit Weight	PSE Unit : 38g , PD Unit :38g
Case of Materials	ABS
Production Location	TW
Certification	FCC, CE, RoHS-compliant