



ANT-19FN-P

2.4GHz 1x1 Outdoor Directional Panel

19dBi Pole Mount Antenna

EAN Code : 4712757152067



ANT-19FN-P provides **18° for H Plane** and **18° E Plane** long distance coverage for point to point application. The **ANT-19FN-P** supports **2.4 to 2.5 GHz** and provides superb performance in IEEE 802.11b/g/n Wi-Fi. It includes a mounting kit with an integrated N Female connector. All materials are considered good in water tightness and prevention of rust characteristics. All CERIO products pass a strict test, and satisfy professional user product needs.

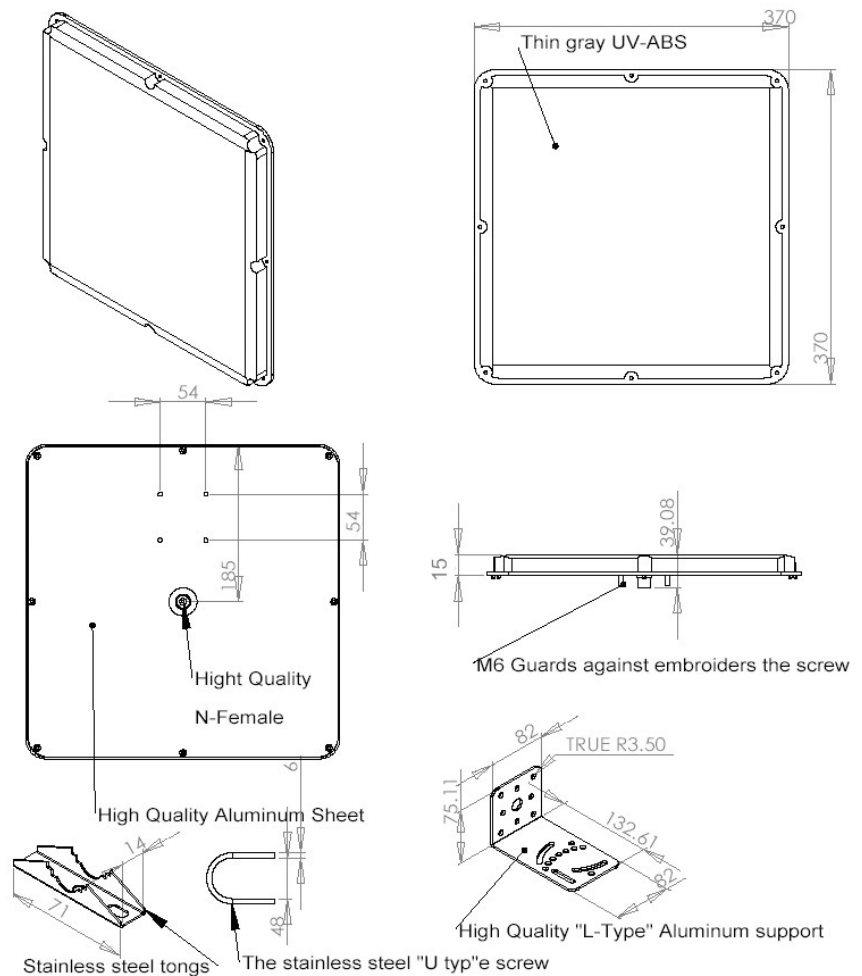



Vertical Pattern Photos

Horizontal Pattern Photos

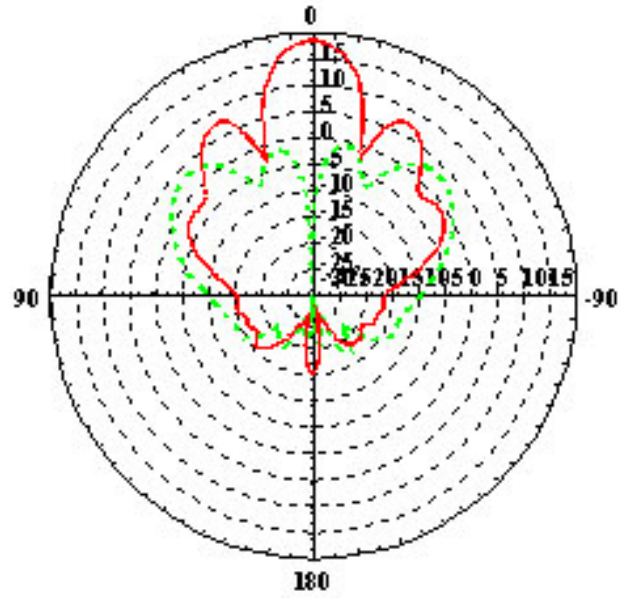
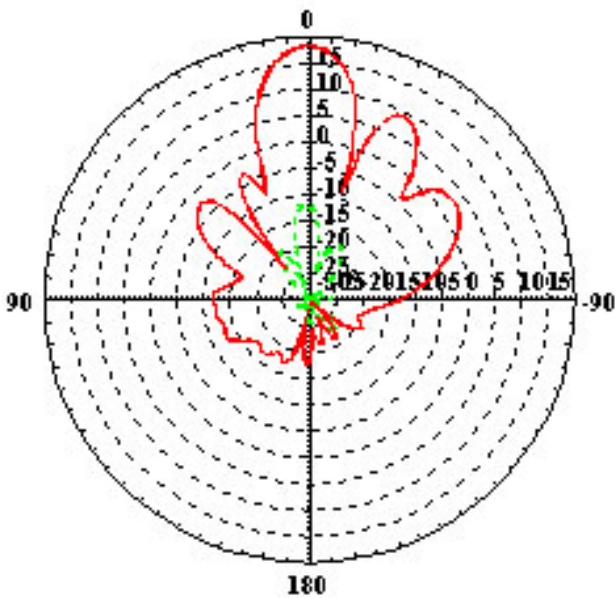

Features

- High gain: 19dBi
- 18° Width-E Plane and 18° Width-H Plane coverage
- High performance
- Light-weight
- Waterproof design
- Easy installation for adjustable down / up wall mount design
- Provide Pole Mount function

Specifications

Antenna Type	Outdoor Directional Panel Antenna
Frequency Range	2.4 ~ 2.5GHz
Network Specification	Wireless 2.4Ghz Network IEEE 802.11n , IEEE 802.11b/g
Gain	19dBi
V.S.W.R	≤1.5
Beam Width-H Plane	18°
Beam Width-E Plane	18°
Polarization	Vertical (Linear)
Input Impedance	50 Ohms
Connector	N-Type Female
Form Factor	Pole Mount (U-Clamps)
Adjustable range	0-30° adjustable wall mount design
Operation Temperature	-50°C - + 85°C
Storage Temperature	-50°C - + 85°C
Humidity	5~90% maximum (non-condensing)
Dimension	373 * 373 *15 mm (L x W x H)
Weight	1.09kg
Production Location	TW Only

Package Content

- ANT-19FN-P Antenna Main Unit x1**
- Pole Mount kit x1**
- Quick Installation Guide Bookletx1**
- Warranty Card x 1**