

ANT-12A

5Ghz Outdoor Omni 12dBi with RF Cable Pole / Wall Mount Antenna

EAN Code : 4712757159790



Introduction

The **CERIO ANT-12A** is a 5GHz 1x1 Outdoor Omni 360° with RF Cable Pole / Wall Mount Antenna. It's perfect solution for extending the range and increasing the signal strength of an outdoor wireless network. It provides a 12°range E Plane coverage for point to multi-point application. The **ANT-12A** supports 5.1 to 5.9 GHz and provides superb performance in IEEE 802.11a/an/ac Wi-Fi. **ANT-12A** all materials are considered good in water tightness and prevention of rust characteristics. All products pass a strict test, and satisfy professional user product needs.

Hardware Overview / Dimension

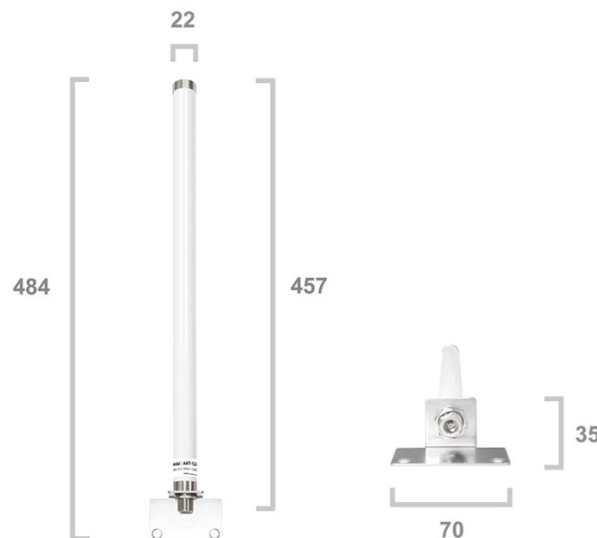

Main Unit Dimension : 457 * 22mm (L x W)
Including bracket : 484 * 70 * 35mm (L x W x H)
Weight : 156g / 216.5g (Including bracket)

Highlight Features

- Supports 5Ghz IEEE 802.11a/an/ac.
- High Gain: 12dBi.
- 360° Width-H Plane and 12°Width-E Plane coverage.
- High performance for Point to Multi-point Applications.
- Light-weight and easy installation.
- IP67 Waterproof design.
- Supports one N-Jack(Female) connector.
- Supports pole & wall mounting.
- Bundle with RF cable with a waterproof cap and pole & wall mounting kit.

Installation Application

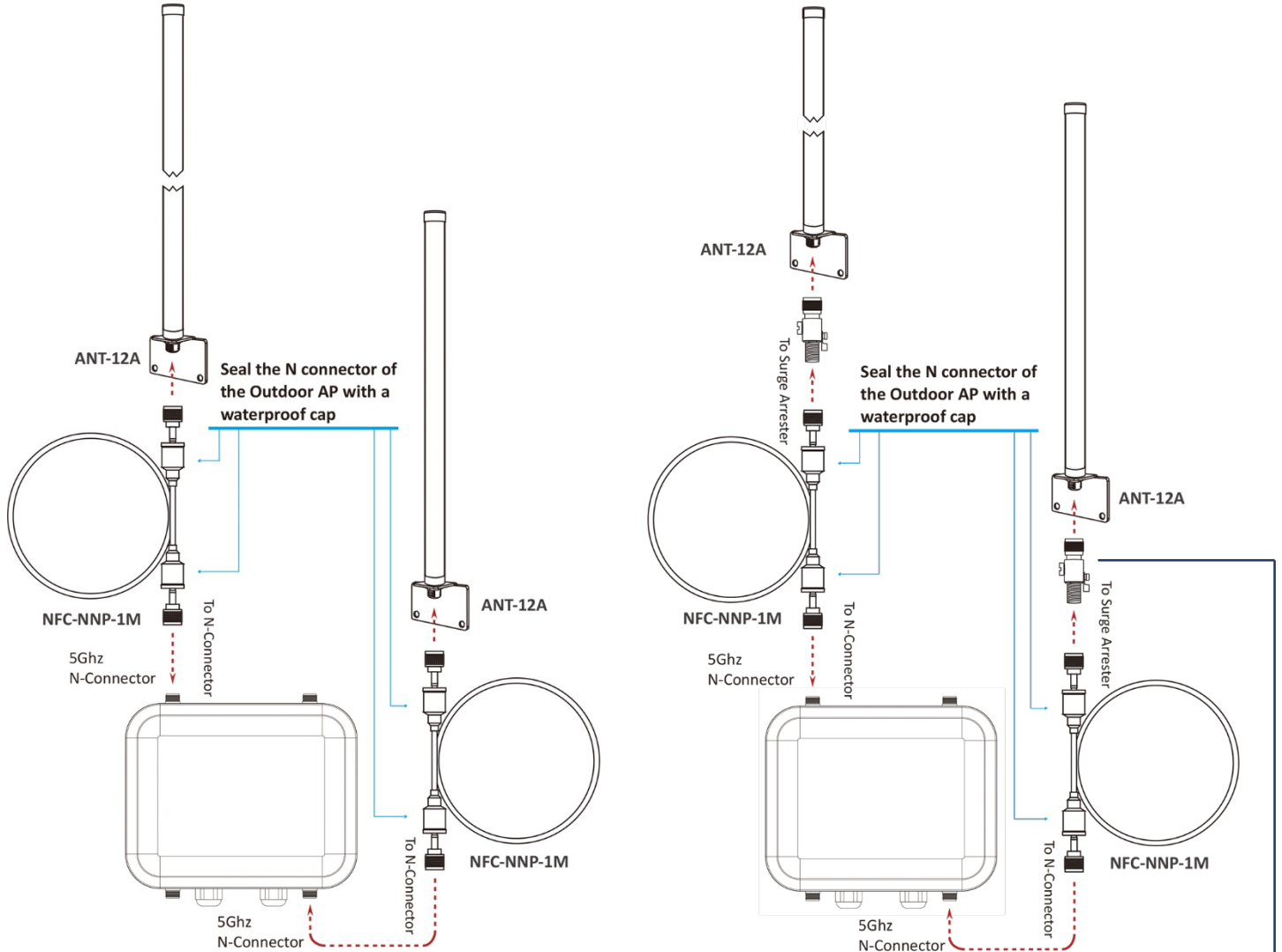

N to N Connector

**Installation with Lightning Protector
(Optional: Model No. LP-300)**

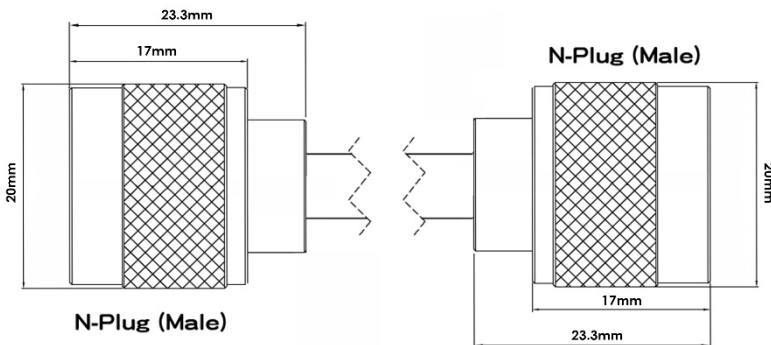

RF Cable Overview (NFC-NNP-1M)

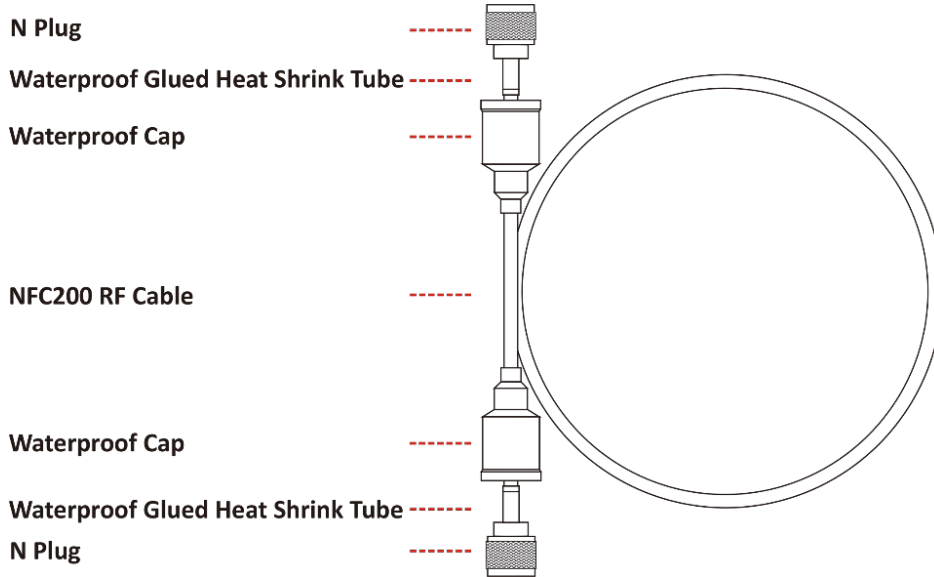

Specifications

Antenna Type	Outdoor Omni Antenna	Operation Temperature	-50°C - + 85°C
Frequency Range	5.1 ~ 5.9GHz (11a/an/ac)	Storage Temperature	-50°C - + 85°C
Network Specification	Wireless 5Ghz Network IEEE 802.11a/an/ac	Humidity	5~90% maximum (non-condensing)
Antenna Gain	12dBi	IP Rating	IP67
V.S.W.R	≤ 2.0	Dimension	Antenna: 457*22 (L x W) mm Antenna with mounting kit: 484*70*35 (L x W x H)mm
Beam Width-H Plane	360°	Weight	Antenna : 156g Antenna with mounting kit : 216.5g
Beam Width-E Plane	12°	Production Location	TW Only
Polarization	Vertical (Linear)		
Input Impedance	50 Ohms		
Connector	N-Type Female x1		
Form Factor	Supports Wall Mounting, Pole Mounting Installation (Pole U-Clamps/Available Pole Range Ø20-Ø52mm)		
Rated Wind Velocity	210Km / Hour		

Package

Package Contents	
ANT-12A Main Unit	x1
Pole & Wall Mounting Kit	x1
RF 1 Meter Cable (NFC-NNP-1M)	x1
Quick Installation Guide	x1
Warranty Card	x1