

## OW-PKUR

### Uniaxial Rotate Stainless Bracket Set (Wall Mount / Hose Clamp / U Bolt)

EAN Codes: 4712757159561

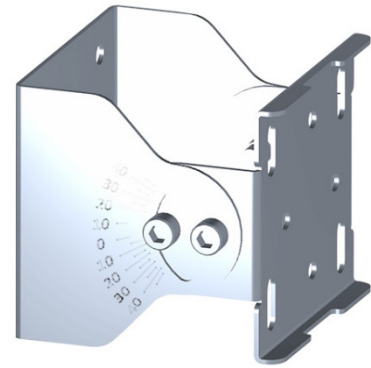

## Introduction

**CERIO OW-PKUR Outdoor Uniaxial Rotate Stainless Bracket Set** is designed for use with outdoor antennas and outdoor AP that have corresponding designs. It supports adjustable wall and pole mounting installation, specifically tailored for outdoor installation equipment and environmental deployments. When used with this bracket for wall or pole mounting, it provides defined directional orientation and adjustable installation. Its stainless steel design is suitable for outdoor applications, protect against weather damage (sun/water/wind). It is an ideal for both indoor and outdoor application.

## Highlight Features

- Adjustable wall/pole mounting applications.
- Durable stainless steel anti-corrosion and anti-rust material design.
- Simple installation and versatile and practical structural design.
- Waterproof and stainless steel materials suitable for all climate applications.
- Supports 45° Vertically up and down adjustable (from 0° to 45°).
- Supports maximum weight load of 5kg.
- Beaufort scale 17 wind load test certificated

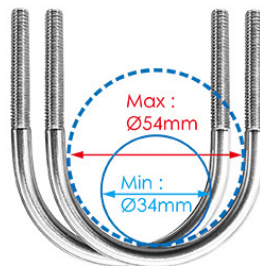
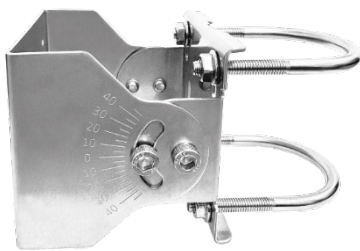

### SUS304 M6 U-bolt

**Available inside diameter : Ø34mm - Ø 54mm**  
Using thickened diameter reaches M6, ensuring installation reliability and excellent wind resistance.

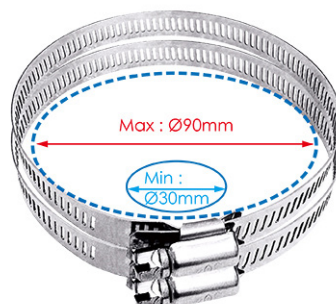

### SUS304 Hose Clamp

**Available inside diameter : Ø30 - Ø90mm**  
Using stainless steel and "full hole" design. No need to worry about hole alignment or loss of strength or durability due to missing holes. Simple and time-saving installation.

**Hardware Overview & Dimension**

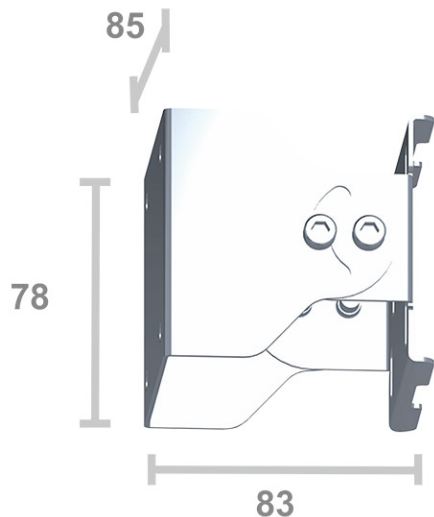

Up 45°

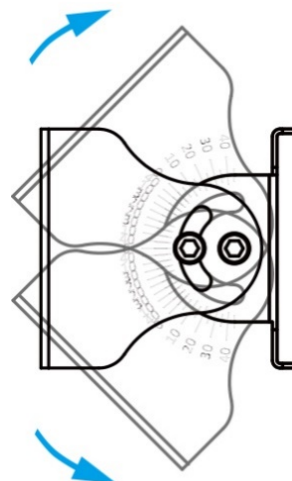

Down 45°

Main Unit Dimension : 83 x85x78mm ( L x W x H )

Weight : 294.6g

**Product Application**

**Wall Mounting**

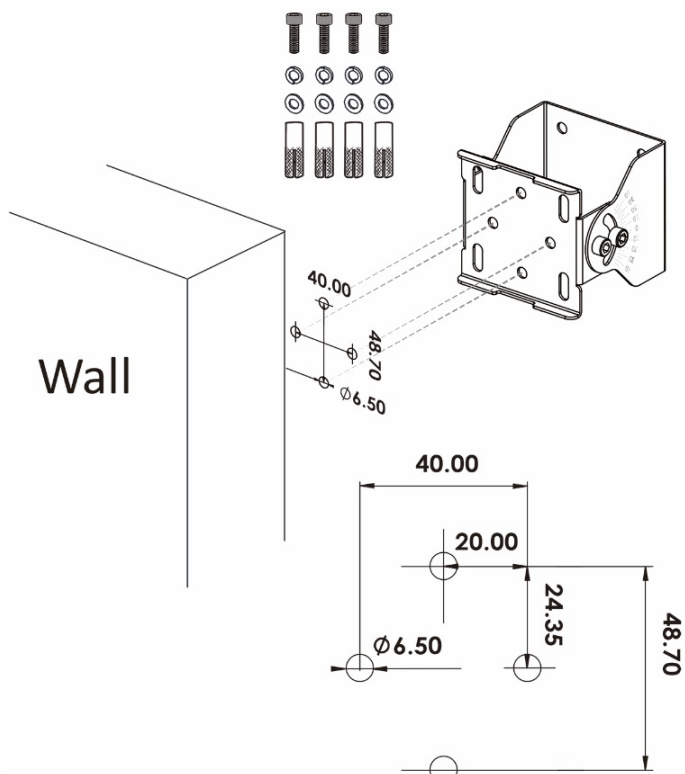

**Pole Mounting**

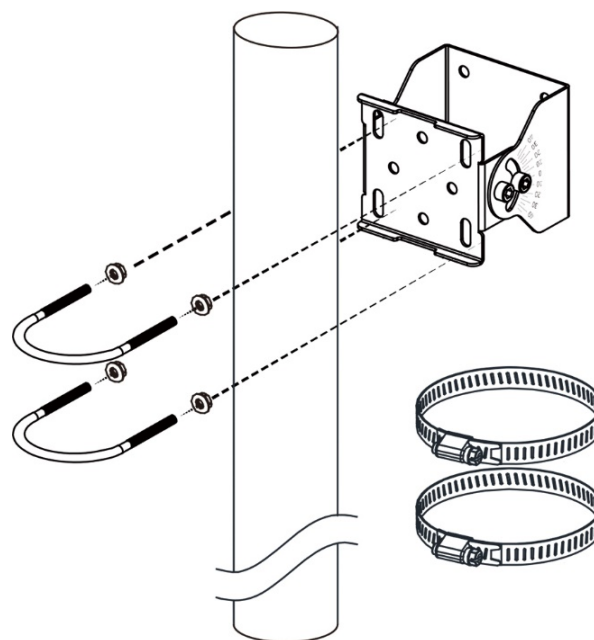

Mount M6 U-bolt or hose clamp to OW-PKUR bracket

## Hardware Specifications

<b>Material</b>	SUS304 Stainless Steel
<b>Device Type Support</b>	Supports Pole/Wall Mounting
<b>Maximum wind resistance velocity</b>	Beaufort scale 17 wind load test certificated
<b>Maximum Weight Support</b>	Supports Max weight of 5kg (After the wall is locked or the pole is locked and fixed)
<b>Adjustable Design</b>	45° Vertical up and down Adjustment Range (0° to 45°)
<b>Operating Temperature</b>	-50°C - + 85°C
<b>Storage Temperature</b>	-50°C - + 85°C
<b>Humidity</b>	5~90% maximum (non-condensing)

<b>Dimensions</b>	<b>Main Unit</b> : 81 x 85 x 78mm ( L x W x H ) <b>Adjustable bracket match SUS304 M6 U-bolt</b> Available inside diameter : Ø34mm - Ø 54mm <b>Adjustable bracket match SUS304 Hose Clamp</b> Available inside diameter : Ø30 - Ø90mm
<b>Weight</b>	294.6g
<b>Production Location</b>	TW

## Package Contents

<b>Contents</b>	
<b>SUS304 Uni-axis bracket with screw set (OW-PKUR)</b>	x1
<b>SUS304 Screw Set</b>	x1
<b>SUS304 M6 U-bolt</b>	x2
<b>SUS304 Hose Clamp</b>	x2
<b>Adjustment/tightening wrench tool</b>	x2